

# ECLIPSE<sup>2</sup>

DOUBLE HUNG



*"The second generation of premium double hung windows"*



REPLACEMENT • REMODELING • NEW CONSTRUCTION

# ECLIPSE<sup>2</sup>

DOUBLE HUNG



A product has never been more aptly named...Trimline's Eclipse<sup>2</sup> double hung truly does "surpass and outshine" its competition with a look that's out of this world. The richly appointed Eclipse<sup>2</sup> double hung has the look and feel of wood windows from a by gone era. The Eclipse<sup>2</sup> blends the ageless style and warmth of a wood interior with the convenience of E-Z tilt sash, a maintenance free aluminum clad exterior and the energy efficiency you'd expect to find in today's windows. The Eclipse<sup>2</sup> double hung features standard combination tilt-lock hardware that is available in a choice of four finishes. Both sash travel in a concealed track system designed to preserve a more authentic looking wood sash pocket, reminiscent of a look and feel from a time ago. Elegantly styled sash lifts or routed finger lifts complete the hardware appointments. All models are furnished standard in pine with Trimline's Comfort E insulating glass system with EnerEDGE<sup>®</sup> warm-edge spacer and argon gas.

## CONCEALED JAMBLINER





## CONCEALED TILT-LOCK MECHANISM

The Eclipse<sup>2</sup> features a combination tilt-lock system, where the tilt mechanism is activated by the lock and is concealed within the lock rail, eliminating the need for surface mount tilt release latches for a neat, clean appearance.

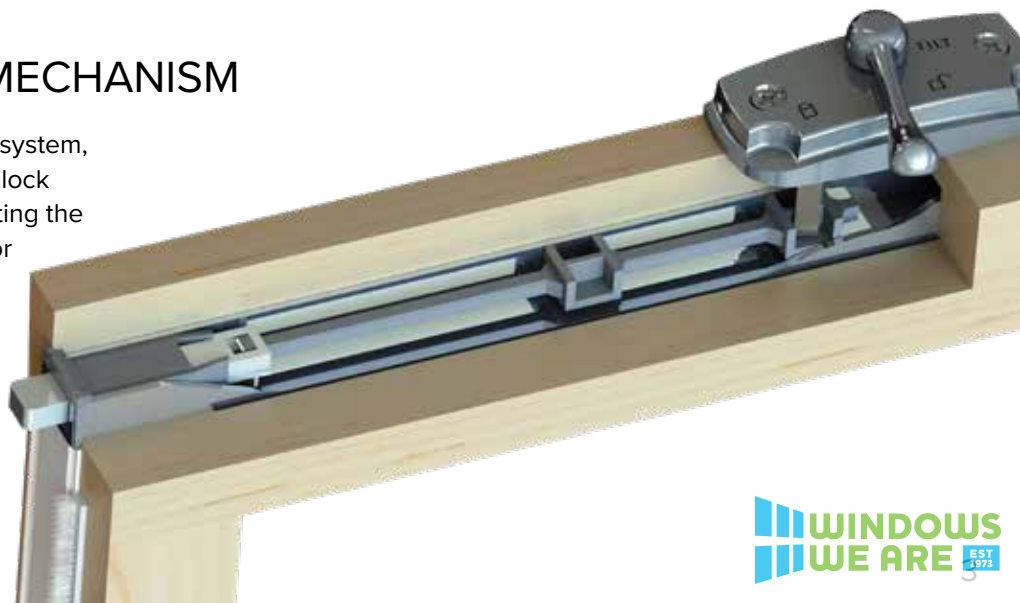



EC300 SHOWN IN BEIGE WITH OPTIONAL 3 1/2" WILLIAMSBURG BRICKMOULD, 1 3/4" HISTORIC SILL AND 5/8" SDL GRILLE.

## CLAD PRODUCTS

**EC200** - Clad double hung with 3 1/4" replacement frame for sash pocket installations from the interior.

**EC200PW** - Use as stand alone picture window or companion picture window with matching sight lines for combination with EC200 units.

**EC200TR**- A transom window to be factory mulled with an EC200.

**EC300** - Clad double hung with full 4 5/16" jamb for remodeling applications where a complete frame tear-out is required or for new construction with nail fin installation. And sash pocket installation from the exterior.

**EC300PW** - Use as stand alone picture window or companion picture window with matching sight lines for combinations with EC300 units.

**EC300TR** - A transom window to be factory mulled with an EC300.

## EXTERIOR CLAD COLORS

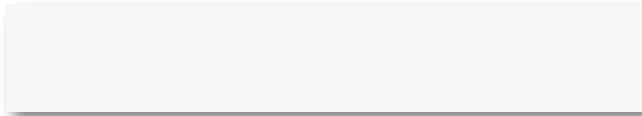

WHITE



BEIGE



EARTHTONE



BRONZE



HUNTER GREEN



BLACK

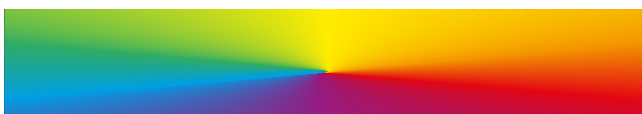

Custom Colors Available

## INTERIOR WOOD SPECIES



PINE (STANDARD)



MAHOGANY



OAK



CHERRY

INTERIOR WOOD CAN BE FACTORY PRIMED, PREFINISHED WHITE, OR PREFINISHED A CUSTOM COLOR. INTERIOR CAN ALSO BE LEFT UNFINISHED FOR STAINING.



TRIMLINE  
WOOD WINDOWS



ENJOY THE BEAUTY  
OF WOOD...  
WITH A MAINTENANCE-FREE  
CLAD EXTERIOR.

The insulating qualities of wood provides a positive thermal break and can be painted or stained, while the weather resistant aluminum clad exterior provides years of maintenance-free durability.

## ACCESSORY PANNING

The EC300 is designed for both residential and commercial remodeling applications where a full frame replacement is required or for sash pocket installations where an extruded aluminum panning system can be used to cover the old window casings. The EC300 is also ideal for use in renovations where the old window has been completely removed, and an accessory brickmoulding is required to fill the void left from the old window casings. Custom designed brickmoulding and panning profiles are available.



SASH POCKET INSTALLATION WITH EXTRUDED ALUMINUM "MERIDIAN" PANNING



## CLAD ANGLE BAY WINDOWS

Angle bays are available with either picture window or double hung centers which can be arranged in a variety of combinations by choosing from four different flanker widths and with 30° or 45° degree mullion angles.



## BAY WINDOW PROJECTIONS

The projection of a custom bay window is the measurement taken from the outside face of the exterior building sheathing to the furthest outside point of the window. It is determined by the Mullion Angle and the Flanker Width specified as shown in the Angle Bay Projection Guide below. The size of the Center Unit is also determined by Mullion Angle and Flanker Width. It is determined by subtracting the Total Flanker Allowance (Flanker Allowance x 2) from the overall unit opening with.

ANGLE BAY GUIDE			
ANGLE	FLANKER WIDTH	TOTAL FLANKER ALLOWANCE	PROJECTION
30°	1'5"	35"	10-3/8"
	1'8"	40-1/4"	11-7/8"
	2'0"	47-1/8"	13-7/8"
	2'4"	54-1/8"	15-7/8"
45°	1'5"	31-3/4"	14-3/4"
	1'8"	36-1/8"	16-7/8"
	2'0"	41-3/4"	19-3/4"
	2'0"	47-1/2"	22-1/2"

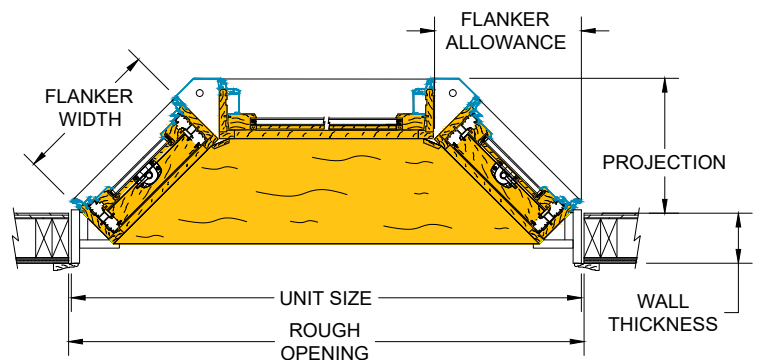

## COMBINATION UNITS

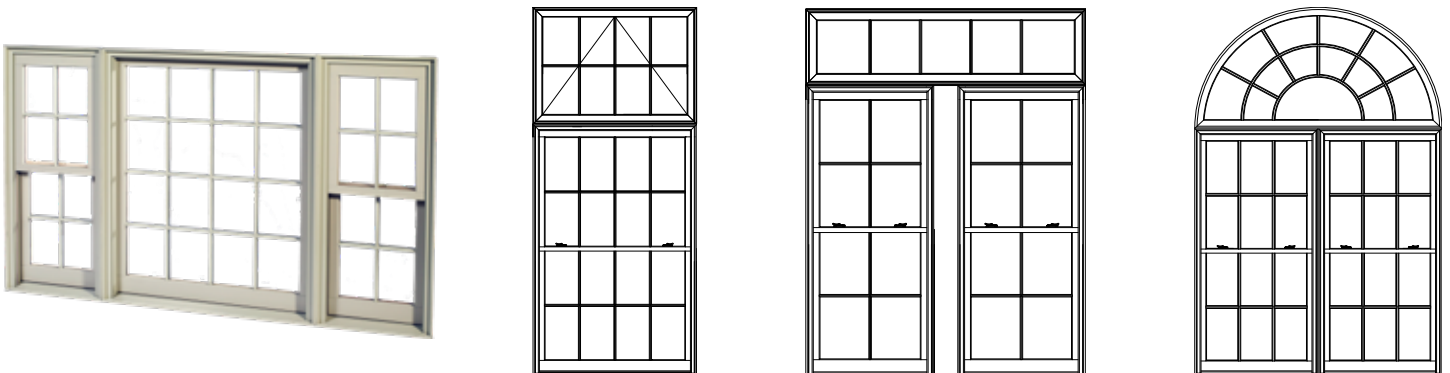

## WOOD PRODUCTS

**EW200** - Wood double hung with 4 9/16" replacement frame for sash pocket installations from the interior.

**EPW200** - Use as stand alone picture window or companion picture window with matching sight lines for combination with EW200 units.

**EW200TR**- A transom window to be factory mulled with an EW200.

**EW300** - Wood double hung with full 4 9/16" jamb for remodeling applications where a complete frame tear-out is required or for new construction with nail fin installation.

**EPW300** - Use as stand alone picture window or companion picture window with matching sight lines for combinations with EC300 units.

**EW300TR**- A transom window to be factory mulled with an EW300.



ERF 400 SHOWN IN PINE WITH 7/8" SDL CUSTOM DECORATIVE GRILLE



EW300/EW300TR SHOWN IN MAHOGANY WITH OIL RUBBED BRONZE HARDWARE & 7/8" SDL GRILLE

## WOOD SPECIES



PINE (STANDARD)



MAHOGANY



## DOUBLE-HUNG ARCH & HALF ROUNDS



ERF400<sup>(1)</sup>  
Arched  
Frame & Sash



ERS400  
Square Frame /  
Arched Sash



ERS400RB  
Square Frame /  
Arched Sash w/ Radius Brickmould



ERF500<sup>(2)</sup>  
Half Round  
Frame & Sash



ERS500  
Square Frame / Half Round  
Sash



ERS500RB  
Square Frame / Half Round Sash w/  
Radius Brickmould

(1) ERF200A also available with replacement frame for sash pocket installation.

(2) ERF200H also available for replacement/sash pocket installation.

All above shown exterior view with standard 1 1/8" sill and standard 908 brickmould

## ARCH & HALF-ROUND GRILLE PATTERNS

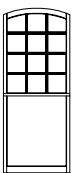

COLONIAL

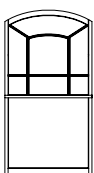

RENAISSANCE

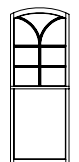
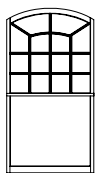
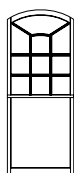

GOthic

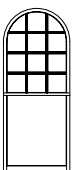
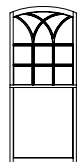

COLONIAL

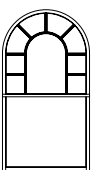

PALLADIAN

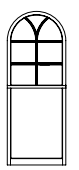
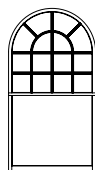
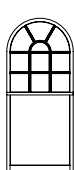

GOthic

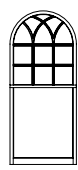

## OPTIONAL RADIUS INTERIOR CASINGS

FOR USE WITH  
ER400 & ERF500



2 1/4"  
Beaded  
Colonial

3 1/4"

## WOOD BRICKMOULDS



EW300 SHOWN WITH 2" BEADED BRICKMOULD AND 1 3/4" HISTORIC SILL



BULLNOSE  
1 7/16" x 1 1/2"



WP 908  
1 1/4" x 2"



BEADED  
1 1/4" x 2"



HARTFORD  
1 3/8" x 1 5/8"

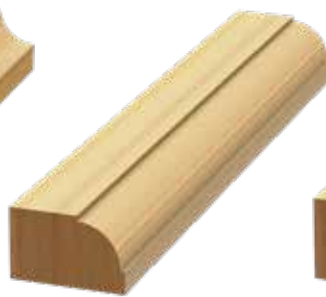

FAIRMONT  
1 1/4" x 2"



JEFFERSON  
1 5/8" x 1 3/8"



LEXINGTON  
1 1/4" x 3 1/2"



EW200  
1/2" REPLACEMENT SILL  
NO BRICKMOULD



EW300  
1 1/8" STANDARD SILL  
2" BEADED BRICKMOULD



EW300 WITH 1 3/4" HISTORIC SILL  
LEXINGTON BRICKMOULD

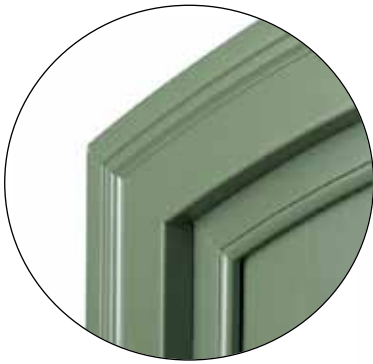

WP 908 BRICKMOULD

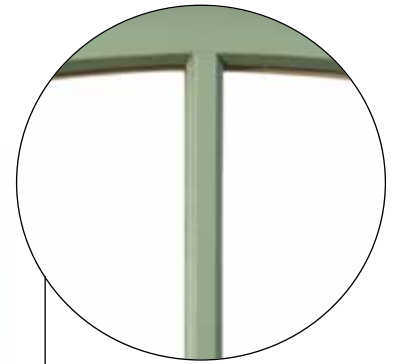

7/8" SDL



ERF400



OPTIONAL 1 3/4" HISTORIC SILL



OPTIONAL HISTORIC SASH POCKET COVER



# FREEDOM FRAME

## OPTIONAL NO-ROT CPVC

Trimline's no-rot "Freedom Frame System" is made from cPVC (cellular polyvinyl chloride) which is a type of rigid plastic foam material that has been engineered to imitate the properties of wood. It not only mimics most of wood's virtues but also gives you the "Freedom" from the maintenance that the exterior of a wood window frame routinely requires. The material can be cut, milled, nailed, screwed, shaped, routed and bent but unlike wood it is nonporous and will not warp, cup, twist, split, check or rot. The design and dimensions of the profiles used in the Freedom Frame system successfully achieves the classic look and feel of a traditional wood window frame. You can further compliment the character of the window and your home by selecting from your choice of 12 exterior brickmould styles which are available with each and every style, shape, and size of the Eclipse<sup>2</sup> series window. Further enhancing the traditional wood window look is the Freedom Frame's ultra smooth, moisture repellent surface which is pre-primed ready for acceptance of your finish coat or your Eclipse<sup>2</sup> window can be ordered prefinished with a high quality factory applied finish in virtually any color. The ability to bend and shape cPVC enable its use in a variety of processes and applications...and like wood, it can be cut, nailed, shaped, routed and bent.



EW200  
1/2" REPLACEMENT SILL  
NO BRICKMOULD



EW300  
1 1/8" STANDARD SILL  
908 BRICKMOULD



EW300 WITH 1 3/4"  
HISTORIC SILL  
3 1/2" FLAT BRICKMOULD

## cPVC BRICKMOULDS

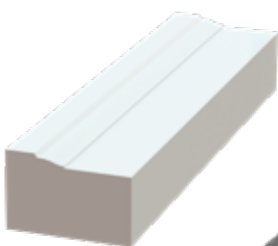

908  
1 1/4" x 2"



908 w/ Foldable Nail Fin  
1 1/4" x 2"

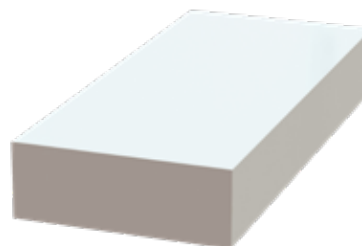

FLAT  
1" x 3 1/2"



ADAMS  
1" x 3 1/2"



## SCREEN STYLES

AVAILABLE IN FIBERGLASS, WIRE, or UltraVue®

EXTERIOR  
FULL SCREEN

EXTERIOR FIXED  
HALF SCREEN



EXTERIOR SLIDING  
HALF SCREEN  
Available on EC200 only



INTERIOR SLIDING  
HALF SCREEN  
Available on all products

## SCREEN FRAME COLORS

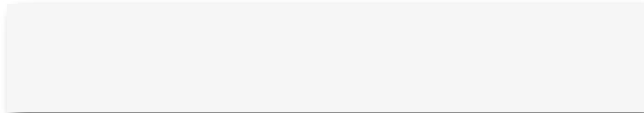

WHITE



BEIGE



EARTH TONE



BRONZE



HUNTER GREEN



BLACK



## TILT-LOCK



SATIN NICKEL



OIL RUBBED BRONZE



BEIGE



WHITE

## SASH LIFTS



SASH LIFT SHOWN IN SATIN NICKEL



OPTIONAL ROUTED FINGER LIFTS

## WOOD

All wood components are milled to precision and treated with a wood preservative and are paintable or stainable to match your existing woodwork and room decor. All exterior wood parts are factory primed.



## CLADDING

For standard colors, the extruded aluminum frame is a spray applied PPG Polycron III finish meeting the physical test requirements of AAMA 2603. Standard colors are also available in optional AAMA 2604 or 2605 finishes. The roll formed sash cladding is a reverse roll-coat system using 70% Kynar resin, meeting the physical test requirements of AAMA 2605. All custom colors meet the physical test requirements of AAMA 2605.



## PRE FINISHING



Trimline utilizes a high-performance Sherwin-Williams product, Kem Aqua BP Enamel, a low-VOC polyurethane-acrylic enamel topcoat developed specifically for in-shop finishing of windows. Kem Aqua BP Enamel provides excellent adhesion on both wood and cPVC composites, with exceptional long-term exterior durability. Kem Aqua BP Enamel's unique resin technology provides excellent color and gloss retention so colors keep their original depth and gloss longer, meeting the strict requirements of both the American Architectural Manufacturers Association (AAMA) as well as the Window and Door Manufacturers Association (WDMA). A wide range of color options makes it easy to achieve clean whites, popular earth tones, and rich, custom colors...virtually any custom color can be matched.

At the heart of Trimline's prefinishing process is the Prime Heat HalCon curing tunnel which uses halogen short wave heating elements to convert electrical energy into shortwave infrared, which penetrates deeper and faster into the finish coating, promoting a more durable and consistently smoother finish by curing from the inside out.



## FINISHING OPTIONS



	INTERIOR		EXTERIOR		
	PINE & MAHOGANY	OAK & CHERRY	CLAD	PRIMED	PREFINISHED
CLAD	PRIMED OR PREFINISHED	NATURAL UNFINISHED ONLY	6 STANDARD COLORS + CUSTOM COLORS		
WOOD	PRIMED OR PREFINISHED			STANDARD	OPTIONAL



CUSTOM TWO-TONE FINISHES AVAILABLE

## FLAT IN-GLASS ALUMINUM

Maintenance-free 5/8" between the glass flat aluminum muntin in matching exterior cladding color. Also available in diamond lite patterns.



## SCULPTURED IN-GLASS ALUMINUM

Maintenance-free 3/4" between the glass sculptured aluminum muntin in matching exterior cladding color.

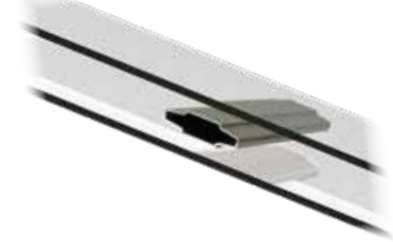

## WOOD REMOVABLE

Wooden removable interior grille available in 5/8" or 7/8"



## REVERSE COMBO

Choose between either maintenance-free 5/8" flat or 7/8" sculpted in-glass grille with either an extruded aluminum, cPVC, wood, or wood exterior grille.

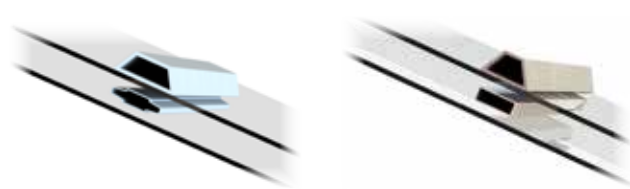

## STANDARD GRILLE WIDTHS



5/8"



7/8"



1 1/4"



1 1/2"

## COMBO WOOD-ALUMINUM

Wood interior grille available in removable or permanently applied 5/8" width which overlays a maintenance-free flat in-glass aluminum muntin in matching exterior cladding color.



## SIMULATED DIVIDED LITE

An authentic "putty glaze" look is achieved with the simulated divided lite (SDL) grille package in either 5/8" or 7/8" widths. The standard SDL system included permanently applied exterior aluminum/wood/cPVC muntins with the choice of removable or permanently applied wooden interior grilles. Also available with optional in-glass bronze spacer bar as shown.



## TRUE DIVIDED LITE

Divides sash into individual panes of glass.





## 1 3/4" THICK SASH OPTION WITH COPED GRILLE



COPED GRILLE



All Eclipse<sup>2</sup> Double Hung windows are available in equal, cottage, or reverse cottage sash configurations.

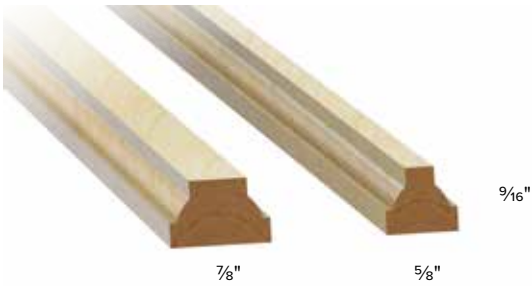

EQUAL

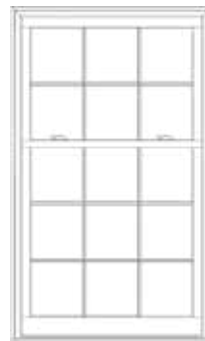

COTTAGE



ORIEL

## BOTTOM RAIL



STANDARD 3 1/4"



OPTIONAL 4" HISTORIC

## WOCD

An optional Window Operating Control Device is available on all double hung products and serves as a safety feature to only allow the bottom sash to open less than 4 inches when activated.



# FEATURES & BENEFITS



## REMODELING OR NEW CONSTRUCTION

(EC300 / EW300)

- For new openings or remodeling installations requiring complete frame tear-out
- Standard 4  $\frac{9}{16}$ " jamb depth
- Applied extension jambs up to 7  $\frac{1}{2}$ "
- Factoring mulling with historic spread mull options
- Choice of factory applied exterior casings
- Optional 1  $\frac{3}{4}$ " historic sill nose
- Optional snap-in pre-slotted hinged vinyl installation flange
- Factory mulling with continuous sill up to 12' on EW300



## POCKET INSERT

(EC200 / EW200)

### EC200

- 3  $\frac{1}{4}$ " stepped jamb for sash pocket insert installation from the interior
- Frame thickness is  $\frac{11}{16}$ " at jamb and head
- Overall sash thickness 1  $\frac{9}{16}$ "

### EW200

- Jamb depth of 4  $\frac{9}{16}$ " with optional screen stop: 5  $\frac{1}{16}$ "
- Overall sash thickness of 1  $\frac{1}{2}$ "
- Sill is  $\frac{1}{2}$ " thick on a 9 degree angle and is designed for a sash pocket insert installation from the exterior (existing blind stop may need to be trimmed)
- Exterior window height is  $\frac{1}{16}$ " greater than interior height



ALL WOOD

(EW200 / EW300)



CLAD

(EC200 / EC300)

- Blindstop, Simulated Divided Light, Sill and optional Screen stop are manufactured from western pine or mahogany (optional cPVC available)
- Optional No-rot cPVC Freedom Frame
- Twelve no-rot cPVC brickmould styles to choose from or custom profiles
- Snap-fit brickmould profiles available
- Freedom Freedom accepts snap-in folding nail-flange

- The insulating qualities of wood provides a positive thermal break and can be painted or stained while the weather resistant aluminum clad exterior provides years of maintenance free durability.
- All frame exterior parts are of .060 maintenance-free extruded aluminum and mitered corners are silicone filled and tightly joined mechanically with concealed corner key.
- A thermally broken tri-plex sill system of wood, extruded aluminum and vinyl is mechanically fastened, gasket and silicone sealed to the jamb
- For standard colors, the extruded aluminum is spray applied PPG Polycron III finish meeting the physical test requirements of AAMA 2603. The roll formed sash cladding is a reverse roll-coat system using 70% Kynar resin, meeting the physical test requirements of AAMA 2605.
- All custom colors meet the physical test requirements of AAMA 2605.

SIZE LIMITATIONS					
	Min. Width	Min. Height	Max Width	Max Height	Max U.I.
EW200	14"	24"	48"	84"	132"
EW300	14"	24"	54"	96"	156"
EPW200	14"	24"	60"	84"	144"
EPW300	14"	24"	72"	96"	156"
EC200	14"	24"	48"	84"	132"
EC300	14"	24"	48"	84"	132"
EC200PW	14"	14"	84"	96"	132"
EC300PW	14"	14"	84"	96"	156"

# PERFORMANCE

Trimline Windows has Energy Performance Certification from the National Fenestration Rating Council (NFRC) as well as Energy Star certification from the U.S. Department of Energy. Energy Star is the national symbol for energy efficiency. These energy performance criteria offer the consumer the only reliable method for comparing different window products as the NFRC / Energy Star rating system is based on total product performance. All testing is conducted at an independent lab.

**U-Factor** measures how well a product prevents heat from escaping a home or building. U-Factor ratings generally fall between 0.20 and 1.20. The lower the U-Factor, the better a product is at keeping heat in.

**Solar Heat Gain Coefficient (SHGC)** measures how well a product blocks heat from the sun. SHGC is expressed as a number between 0 and 1. The lower the SHGC the better the product is at blocking unwanted heat gain. This is especially important during the summer cooling season.

**Visible Transmittance (VT)** measures how much light comes through a product. The higher the VT the higher the potential for day lighting.

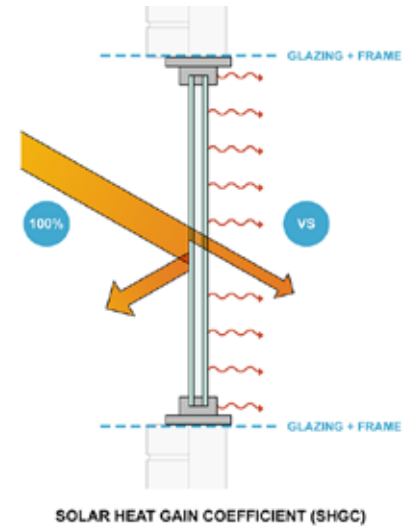

	NFRC Thermal Performance									AAMA/WDMA/CSA101/1.S.2/A440	
	U-Factor		No Grids		Grids <1"		TDL		CRF	Air Infiltration	Performance Class-Grade Design Pressure
	No Grids or <1" Grids	TDL Grids	SHGC	VT	SHGC	VT	SHGC	VT			
<b>Clad</b>											
EC200 Comfort E Comfort E Plus	.30 .27		.28 .27	.50 .49	.25 .24	.44 .43			57 47	.08 cfm/ft <sup>2</sup>	LC-45 DP45
EC300 Comfort E Comfort E Plus	.29 .26		.28 .27	.50 .49	.25 .24	.44 .43			57 47	.08 cfm/ft <sup>2</sup>	LC-45 DP45
EC200PV, EC300PV Comfort E Comfort E Plus	.29 .26		.29 .28	.52 .51	.26 .26	.47 .45			59 48	.03 cfm/ft <sup>2</sup>	CW-60 DP60
<b>Wood</b>											
EW200 Comfort E Comfort E Plus	.28 .25	.33 .31	.28 .27	.50 .49	.25 .24	.44 .43	.22 .22	.39 .38	57 47	.14 cfm/ft <sup>2</sup>	LC-40 DP40
ERS200A, ERS200H, ERF200A, ERF200H Comfort E Comfort E Plus	.28 .25	.33 .31	.28 .27	.50 .49	.25 .24	.44 .43	.22 .22	.39 .38	57 47	.14 cfm/ft <sup>2</sup>	LC-40 DP40
EW300, ERS400, ERS400RB, ERS500, ERS500RB, ERF400, ERF500 Comfort E Comfort E Plus	.29 .26	.33 .31	.28 .27	.49 .48	.25 .24	.44 .42	.22 .22	.38 .37	57 47	.14 cfm/ft <sup>2</sup>	LC-40 DP40
EPW200, ERSPW200A, ERSPW200H, ERFPPW200A, ERFPW200H Comfort E Comfort E Plus	.28 .24	.33 .30	.29 .28	.52 .51	.26 .26	.46 .45	.24 .23	.41 .40	60 49	<.01 CFM/ft <sup>2</sup>	CW-40 DP40
EPW300, ERSPW400, ERSPW400RB, ERSPW500, ERSPW500RB, ERFPPW400, ERFPW500 Comfort E Comfort E Plus	.28 .25	.33 .30	.29 .28	.52 .51	.26 .26	.46 .45	.24 .23	.41 .40	60 49	<.01 CFM/ft <sup>2</sup>	CW-40 DP40

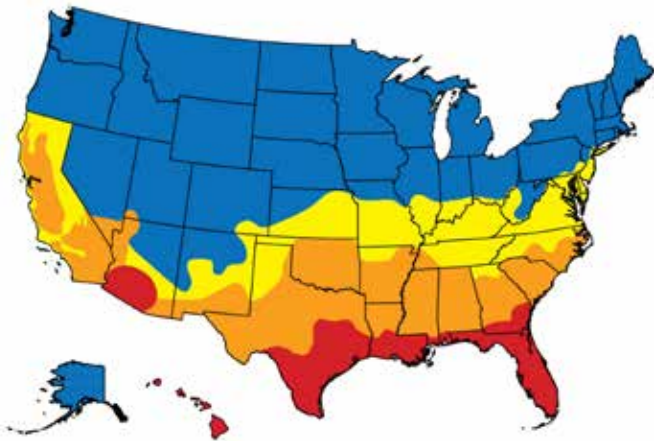

ENERGY STAR® for Windows, Doors, and Skylights CLIMATE ZONE MAP			
Climate Zones - U.S.		U-Factor	SHGC
Northern	Northern	$\leq 0.27$	Any
	Northern	$= 0.28$	$\geq 0.37$
	Northern	$= 0.30$	$\geq 0.42$
North-Central	North-Central	$\leq 0.30$	$\leq 0.40$
South-Central	South-Central	$\leq 0.30$	$\leq 0.25$
Southern	Southern	$\leq 0.40$	$\leq 0.25$

 COMFORT 

 COMFORT   
 PLUS

Energy Star windows reduce household energy bills by 7-15 percent. The rate of heat loss through a window is determined by the U-Factor (U-Value). The lower the U-Value number, the better the insulating properties. In the same spectrum, the better the insulating properties, the more money will be saved on heating and cooling costs. When windows account for almost one quarter of household energy, investing in a Trimline window is the perfect solution.

Warm Edge refers to the type of spacer material used to separate the panes of glass in an insulating unit. Many of today's energy efficient windows offer glass packages touting "Warm Edge Technology"... the problem is, these new windows often use thermally conductive metal-based spacers in their insulating glass systems.

#### Homeowner Benefits

- Increased comfort - any climate, any season.
- Reduced heating and cooling bills.
- Protection from UV rays that can fade carpet, walls and furniture.
- Color- neutral for crisp, clear views.
- Helps keep indoor humidity at comfortable and healthy levels by keeping glass warmer, which in turn minimizes health issues caused from mold and mildew.
- Warm-edge spacer virtually eliminates condensation
- Helps homes stay cooler in the summer & warmer in the winter.
- When combined with double strength glass EnerEDGE substantially reduces noise.

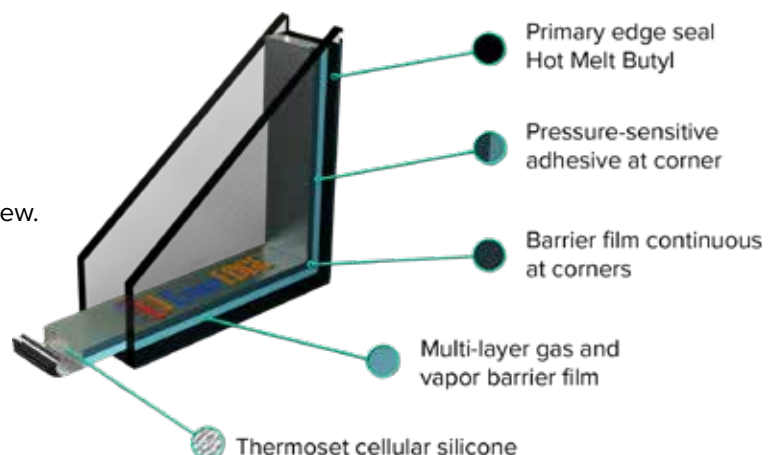

## POCKET INSERT REPLACEMENT FRAME

CLAD DOUBLE HUNG  
(EC200)

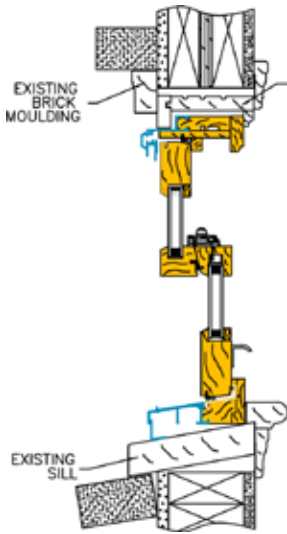

CLAD PICTURE  
(EC200PW)

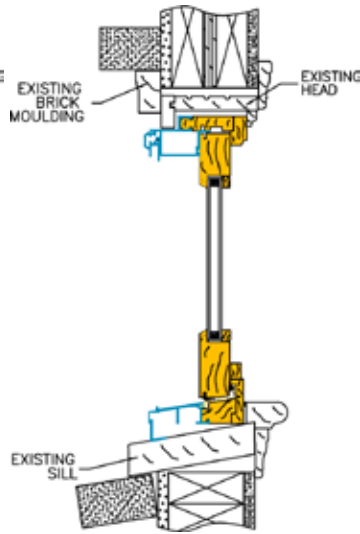

WOOD DOUBLE HUNG  
(EW200)

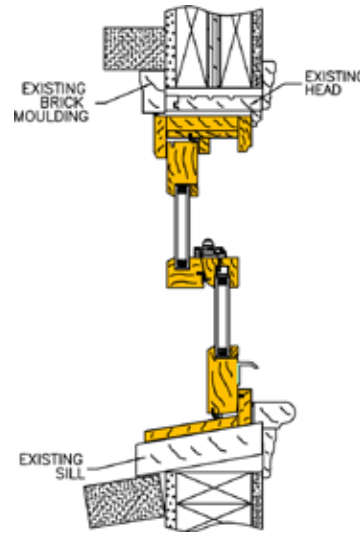

WOOD PICTURE  
(EPW200)

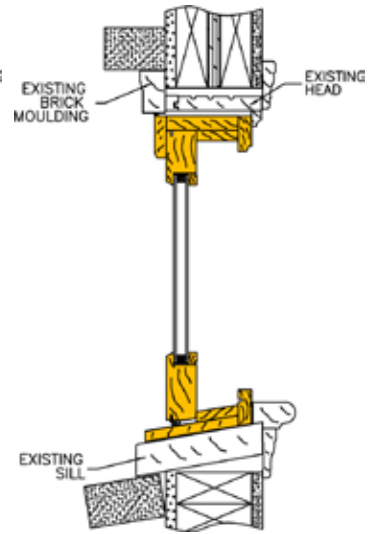

## REMODELING OR NEW CONSTRUCTION FULL FRAME

CLAD DOUBLE HUNG  
(EC300)

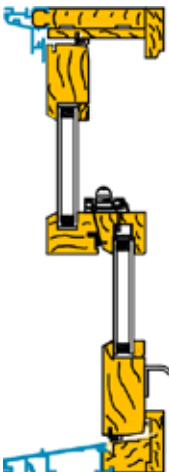

CLAD PICTURE  
(EW300)

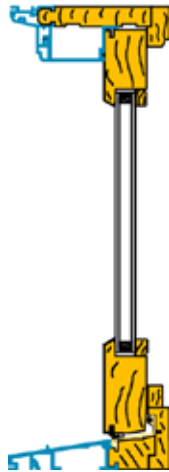

WOOD DOUBLE HUNG  
(EW300)

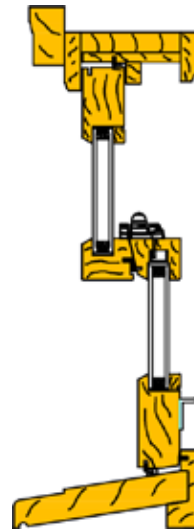

WOOD PICTURE  
(EPW300)

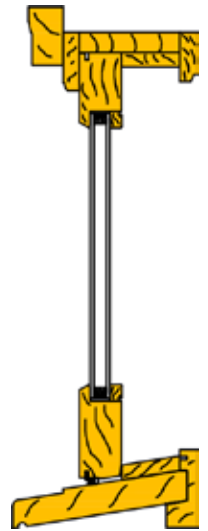

Trimline Windows, Inc.  
**NON-PRORATED 10/20 YEAR  
WOOD WINDOW LIMITED WARRANTY**



Trimline Windows, Inc. warrants its Clad Wood, and All Wood windows and Sash Replacement kits to be free from material defects for the period(s) as set forth below:

**WHO IS COVERED**

This limited warranty extends to the original purchaser of the window for the period(s) as described below from the purchase date of the window.

**WHAT IS COVERED**

The vinyl and aluminum extrusions and wood components used in the window are warranted to be free from defects under normal use and service and are warranted not to pit, rot, rust, flake, corrode, peel or blister for ten (10) years from date of purchase. The insulating glass is warranted against defects resulting in material obstruction of vision from film formation, dust collection or moisture collection within the sealed glass for twenty (20) years from date of purchase, non square and decorative/leaded insulated glass is warranted for five years. The hardware and other components or accessories are warranted against defects under normal use, care and cleaning for ten (10) years from date of purchase. Repairs of any defects that arise or become manifest after the expiration of the warranty period are not the responsibility of Trimline Windows, Inc.

**WARRANTY CLAIM PROCEDURE**

Any claims of defects under this warranty are to be made in writing to Trimline Windows, Inc., Northampton Business & Technology Center, 50 Louise Drive, Ivyland, PA 18974, Attn: Warranty Claim Dept. Claims should be made within ten days of the discovery of the suspected defect. Included with the claim must be a copy of this warranty showing installing contractor's name and date of installation and proof of original purchase date. If the windows are found to be in non conformance with the terms of this warranty, Trimline Windows, Inc. agrees, at its option, to repair or replace the defective part(s). Field service costs to repair or replace defective part(s) will not be charged by Trimline Windows, Inc. for a period of one year following the date of original purchase. After the first year Trimline Windows, Inc. will not be responsible for any field service labor or transportation costs incurred in the repair, removal, replacement, installation of the window or any window component. Service calls will be charged at the then prevailing rate for labor and mileage.

**REPLACEMENT PARTS**

Trimline Windows, Inc. reserves the right to discontinue or change any of its products or the parts utilized in any of its products at its sole discretion. If any window product or component originally installed in the building is not available at the time of any claim by you under this warranty, Trimline Windows, Inc. reserves the right to substitute any other model or component as a replacement.

**EXCLUSIONS**

Trimline Windows, Inc. does not warrant installation or claims caused by installation. This warranty covers manufacturing defects only and does not include damage or defects due to normal weathering, fading, accidents or intentional damage, hail, lightening, flood, fire, acts of God, building settlement or structural failure, chemical pollutants, mildew, improper maintenance, vandalism or any other cause beyond the control of Trimline Windows, Inc. This warranty does not cover windows where the cladding has been painted, varnished or coated with any substance by the consumer. Broken glass and screens are not covered. Condensation of moisture on the exterior surfaces of the sealed glass in the window may occur as a natural result of excessive humidity within the building area. Changes in interior and exterior temperatures may also cause condensation. It does not indicate a window defect and is not covered by this warranty.

THE MANUFACTURER WILL HAVE NO LIABILITY BEYOND REPAIR OR REPLACEMENT AND EXPRESSLY WILL HAVE NO LIABILITY FOR ANY LOSS OF TIME, INCONVENIENCE, LOSS OF USE, PERSONAL INJURY, PROPERTY DAMAGE, OR ANY OTHER INCIDENTAL OR CONSEQUENTIAL DAMAGE. THIS WARRANTY IS THE ONLY ONE WHICH THE MANUFACTURER MAKES AND IS EXPRESSLY IN LIEU OF ANY OTHER EXPRESS OR IMPLIED WARRANTY INCLUDING THOSE OF MERCHANTABILITY OR FITNESS FOR A PARTICULAR PURPOSE AND THE PROVISIONS OF THIS WARRANTY ARE THE EXCLUSIVE REMEDY OF THE PURCHASER. EXCEPT THROUGH WRITTEN AGREEMENT FROM THE MANUFACTURER, NO REPRESENTATIVE HAS ANY POWER OR AUTHORITY TO MAKE ANY ALTERATIONS TO THIS WARRANTY OR ANY PROMISE OR REPRESENTATIONS OTHER THAN THOSE CONTAINED IN THIS WARRANTY. THIS WARRANTY CONTAINS THE ENTIRE AGREEMENT BETWEEN THE PARTIES.

Some states do not allow limitation on how long a warranty lasts or the exclusion of incidental or consequential damage, so the above limitation or exclusions may not apply to you. This warranty gives you specific legal rights and you may have other rights which vary from state to state. This warranty shall be governed by the laws of the Commonwealth of Pennsylvania.

Effective 1/1/2011

# ECLIPSE<sup>2</sup>

DOUBLE HUNG

Distributed Locally By:



**TRIMLINE**  
WOOD WINDOWS

For more than 50 years, Trimline has provided quality custom windows for use in replacement, remodeling, new construction and historically certified rehabilitation projects. Trimline offers a wide variety of products including double hung, casement, bow, bay, awning, picture windows, and sash replacement kits, as well as round top, elliptical and other architectural window products.

Custom colors in either all wood or aluminum clad exteriors and interior hardwoods of oak, cherry, and mahogany are available. Custom extruded panning systems and other trim accessories plus, a variety of simulated divided light as well as authentic true divided lite profiles, and replication of mullion details are some of our custom capabilities.

